

!!!!!!WARNING!!!!!!
BEFORE OPERATING THIS DEVICE CHECK WITH LOCAL
AUTHORITIES FOR PERMITTING OR LICENSING REQUIREMENTS!
THE COMMONWEALTH OF MASSACHUSETTS REQUIRES USERS TO
HOLD A STATE BLASTING LICENSE. FEDERAL BLASTING LICENSES
ARE NOT REQUIRED TO USE OUR SYSTEM IN ANY STATE.
ALWAYS PRACTICE THE HIGHEST STANDARDS OF SAFETY AND
USE ONLY IN WELL-VENTILATED AREAS!

The standard MICRO-BLASTER™ II KIT (1Head) contains the following items. Non-standard kits may contain other components. See the website below or a dealer for optional accessories.

- 1 MICRO-BLASTER™ II HEAD w/25' HOSE
- 1 CO2 INFLATOR (Single Head MB II only)
- 1 HOLE BLOWER ASSEMBLY
- 1 5/16" BORE BRUSH
- 2 TAPERED DRIFT PINS
- 1 MICRO-BLASTER™ II SERVICE WRENCH
- 1 INSTRUCTION MANUAL
- 1 LAMINATED INSTRUCTION CARD
- 1 FIRING PIN EJECTOR ("L" SHAPED PIN)
- 1 TELESCOPING MAGNETIC CARTRIDGE RETRIEVAL TOOL
- 1 SAFETY GLASSES (ANSI APPROVED, Z87.1-1989)
- 1 MOLDED CASE

The Triple Head Kit (MB-IIx3) contains all but the CO2 bicycle inflator plus 2 additional HEADS and a MANIFOLD ASSEMBLY with Lock and Key.

**MICRO-BLASTER™ CARTRIDGES ARE SUPPLIED
SEPARATELY. CONTACT YOUR DEALER OR**

EZEBREAK, LLC,
484 Crane Rd. PO Box 29
Renick, WV 24966 Frankford, WV 24938
888-497-9970

ezebreak@frontiernet.net
www.ezebreak.com

©2002-2026 EZEBREAK, LLC

!!!CAUTION! READ AND UNDERSTAND THESE DIRECTIONS COMPLETELY BEFORE USING THIS DEVICE!!!
SERIOUS INJURY MAY RESULT FROM IMPROPER USE!

!!!!NEVER OPERATE YOUR MICRO-BLASTER™ AT A DISTANCE OF LESS THAN 25 FEET FROM THE MATERIAL YOU ARE BREAKING. WHEN POSSIBLE COVER THE MICRO-BLASTER™ AND THE MATERIAL BEING BROKEN WITH A SUITABLE MAT OR CARPET TO REDUCE THE SOUND AND ELIMINATE FLY ROCK!!!!

SAFETY PRECAUTIONS

- 1. Always wear eye, ear, and hand protection!**
- 2. Protect others by restricting access to your work area. The operator of the Micro-Blaster™ II should always be the closest (minimum 25 feet) to the area of breakage just before and when firing the system. This distance is measured from the end of the hose supplied with your Micro-Blaster™ II. The operator should never shorten this hose in any way. If the hose becomes damaged, hose replacement, in its entirety, is required for safe and consistent operation. Do not splice damaged hoses as any restrictions in the hose will alter the system's ability to trigger the Micro-Blaster™ II heads simultaneously.**
- 3. Before firing the Micro-Blaster™ it is advisable to cover all materials to be broken with heavy carpet or mat, especially when initiating more than one cartridge or Micro-Blaster™ head at once. Although fly rock is not usually a problem, small pieces of material have been observed to travel several feet. Do not take the risk of injuring someone or inadvertently damaging property by not using mats or heavy carpet. These covers will also reduce the sound of a Micro-Blaster™ shot to a low "thump".**

4. When setting up your Micro-Blaster™ for a shot, never connect the end of the hose to a pressure source before everyone is beyond the end of the fully extended hose. When everyone is clear and you are ready to fire, connect the hose or manifold to a pressure source, fire the Micro-Blaster™. After firing, re-lock the slide valve if using the Manifold Assembly or disconnect the pressure source from the single head model. This will maintain your system in a fail-safe mode so that it cannot be inadvertently fired.

5. Keep and transport all Micro-Blaster™ Cartridges in a secure and dry environment in the original 4G shipping cartons. Keep away from children. Initiate only in well-ventilated areas.

MICRO-BLASTER™ INSTRUCTIONS

OVERVIEW

The EZEBREAK MICRO-BLASTER™ operates on the principle of a rapidly expanding gas pulse at the bottom of a drilled and plugged hole, forcing the rock to break. When the MICRO-BLASTER™ Cartridge is fired, the propellant contained within rapidly develops very high pressure. At the moment that the material breaks, it releases this pressure and the burn rate of the propellant drops instantly. This feature accounts for the ability of the system to break a large range of material and to almost entirely eliminate the danger of fly rock.

We strongly recommend that the user practice using this device as much as is reasonably possible in advance of an important project. Because MICRO-BLASTING™ uses very low energy cartridges, its use demands attention to such details as the grain of the material and the distance from a free edge (burden) of the material being broken. Although a great deal of testing has gone into the development of this device, its effective use is dependent on the user's experience and skill. If the material is porous, flawed or cracked, contains voids or is especially soft, i.e. "rotten rock", this system may prove to be ineffective. The breaking action is dependent on the very rapid buildup of pressure upon initiation of the MICRO-BLASTER™ Cartridge. If these gases are allowed to escape too quickly through cracks, etc., there may not be enough force generated to break the material. In situations where one encounters flawed material, material that has been cracked from previous use of a MICRO-BLASTER™, or frost wedging, etc, an alternative technique such as "plugs and feathers" or more simply the use of suitably sized "drift pins" (2 are included with your MICRO-BLASTER™ kit) may prove to be a more effective method. The use of small hand sledges to "coax" cracked rock

apart can often be quite effective also. Placement of cartridges too near the bottom of a rock may also prove ineffective in that the rock may only “blow out” at the bottom. Judgment needs to be exercised to **place the cartridge near the center of the mass to be broken** in order to avoid this problem and gain the maximum effect from each shot. Users attentive to these details, who employ a methodical and safety-oriented approach will develop the necessary skills quickly and be more productive.

EZEBREAK MICRO-BLASTER II™

The EZEBREAK MICRO-BLASTER™ II (MB-II) is operated much in the same way as the original MICRO-BLASTER™ (MB-I). The MB-II offers the distinct advantage of not having to orient drilled holes to accommodate the required right-angle line pull of the MICRO-BLASTER™ I. This advantage gives users the freedom to place holes at angles from 10 degrees above horizontal to straight down into the material being broken. This feature will be especially beneficial when working in confined or difficult to access areas, such as caves, mines, trenches, etc. The operator should always drill holes in a downward direction so that gravity will maintain contact between the tip of the MB-II Firing Pin Tube (8) and the Cartridge at the bottom of the hole when the unit is fired.

Added safety is also gained with the MB-II since the system is never "armed" until the operator connects the bicycle tire inflator (MB-II Kit) or unlocks the slide valve on the MB-IIX3 manifold. Always be sure that everyone is at least 25 feet away from the material being broken before “arming” your system. A further advantage of the MB-IIX3 is the capability of the system to fire two or more MB-II Heads simultaneously. This method can be very effective on larger projects. Before using your MB-II you should become familiar with its design and operation. The MB-II utilizes a unique mechanism (US and International Patents granted) that operates on the principle of a low-pressure pulse, acting on a steel Piston (6) overcoming the force of attraction from an internal Magnet (5). This subsequently applies a striking force to the Firing Pin (9) that fires the MICRO-BLASTER™ Cartridge (see components diagram at end of manual for clarity).

To prepare the MB-II for use, the Piston (6) must be in contact with the Pot Magnet (5), in "latched" position. Turning the unit so that Firing Pin Tube (8) points upward and tapping the black Steel Cap (1) against a solid object will allow the Piston (6) to slide down the internal bore of the Body (7) and "latch" in the firing position against the Magnet (5). If the Piston (6) was not in contact with the internal Magnet (5) beforehand you will hear a

click as it "latches" with the Magnet (5). If you do not hear a click, the Piston (6) may have already been in contact with the Magnet (5), and "latched". To always be sure the Piston (6) is "latched", tap the Steel Plug (1) against a solid object while holding the unit with its Firing Pin Tube (8) pointing up. It is good practice to store your MB-II with the Piston (6) in contact with the Magnet (5), "latched", and to reset the Piston (6) in the "latched" position after each shot in order to prepare it for the next shot. To check the location of the Piston (6), hold the MB-II with the Firing Pin Tube (8) pointing down and look through the vent hole in the side of the MB-II Body (7). The Firing Pin (9) should be protruding from the tip of the Firing Pin Tube (8) at least 1/8". If the Piston (6) is in contact with the Magnet (5) you will be able to see through the Body (7) over the head of the fully extended Firing Pin (9). If you cannot see light through the Body (7), either the Firing Pin (9) is not fully extended (see above) or the Piston (6) is sitting on the head of the Firing Pin (9) and not in the "latched" position against the Magnet (5) above it. If you have already inverted the unit (tip up) and the Piston (6) did not latch, this is an indication that cleaning and lubrication are needed. The Piston (6) should always move freely when not "latched" to the Magnet (5). You can also "dry fire" the unit with the Firing Pin Tube (8) pointing down and in contact with a wood block. After "dry firing", remove your system from the pressure source, then turn the unit so that the Firing Pin Tube (8) is pointing up which allows the Piston (6) to slide down and "latch" with the Magnet (5). If the Piston (6) or the Firing Pin (9) does not move freely the unit should be disassembled, cleaned, lubricated and reassembled. We recommend using a light gun oil, such as RemOil™, to avoid viscosity issues when using the system in cold weather. The MICRO-BLASTER™ II is a precision tool that should always be kept clean and well lubricated for dependable use as well as for protection of its tool steel components against corrosion.

Pressure Sources for Initiating the Micro-Blaster™ II

A minimum of a 75-psi pressure pulse is required to fire the MICRO-BLASTER™ II reliably. **Do not operate from pressure sources above 150 psi!** Your MICRO-BLASTER™ II can be fired by several different pressure sources including, but not limited to, the following:

- CO2 BICYCLE TIRE INFLATOR (single head only)
- "T" HANDLE BICYCLE PUMP (single head only)
- PORTABLE AIR TANK (min. 5 gal)
- REGULATED OUTPUT CO2 CYLINDER (150 psi max.)

Planet Bike Red Zeppelin Instructions:

Step 1: Tighten (close/clockwise) red inflator knob

Step 2: Thread on CO2 canister clockwise

Step 3: Screw inflator onto tire valve fitting clockwise

Step 4: Unscrew red inflator knob counterclockwise to release CO2 into tube

Step 5: Be sure to close red inflator knob to stop CO2 once pressure is reached

Step 6: Once empty please recycle CO2 cartridges

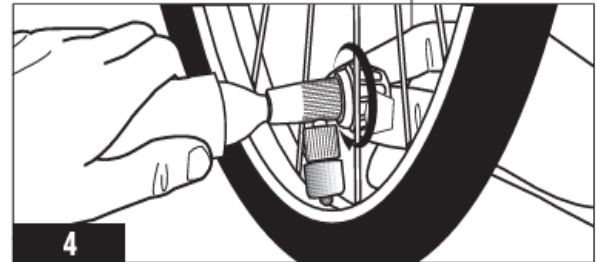
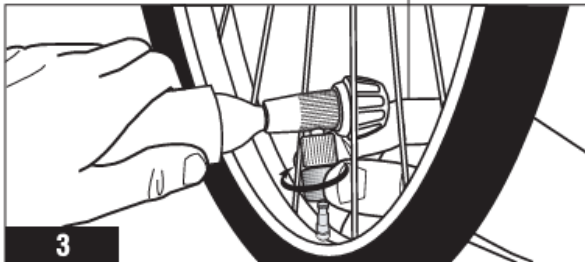
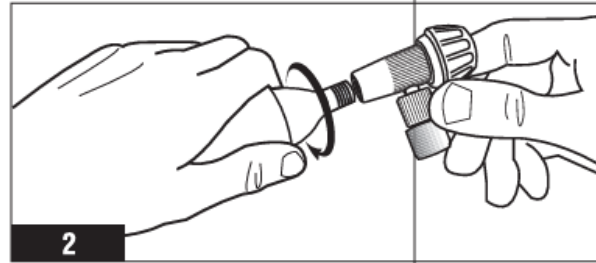
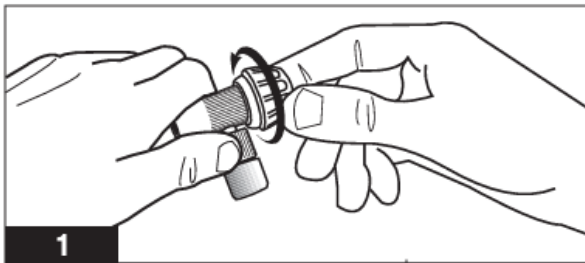

CO2 SAFETY INFORMATION! WARNING-CONTENTS UNDER PRESSURE. DO NOT PUNCTURE OR INCINERATE

<p>Carbon Dioxide</p> <hr/> <p>WARNING Contains gas under pressure; may explode if heated. May cause severe frostbite. May displace oxygen and cause rapid suffocation.</p> <p>PREVENTION Avoid contact with eyes and skin. Use in a well ventilated area. Keep away from heat, open flames, and hot surfaces.</p> <p>RESPONSE If inhaled: Move person to fresh air, make comfortable, and monitor breathing.</p>	<p>Planet Bike 1-866-256-8510 www.planetbike.com</p>
---	--

KEEP OUT OF REACH OF CHILDREN!

Planet Bike offers a limited lifetime warranty on the inflators. Warranty excludes improper or unsafe use, abuse, or any misuse.

Firing Micro-Blaster™ II: Once the unit is charged, connected to the Schrader valve on the end of the MICRO-BLASTER™ II hose (see image 3) Unscrew red inflator knob counterclockwise to release cO2 into tube to fire the MICRO-BLASTER™ II. **Always disconnect inflator from Micro-Blaster™ II hose after firing to avoid inadvertent triggering.** Red Zeppelin is compatible with all threaded cartridges in different sizes which are available in most areas from stores selling paintball and air gun supplies.

Using "T" HANDLE BICYCLE PUMPS (Single Head Only)

When you are ready to fire your MICRO-BLASTER™ II (see instructions immediately following this section), attach the hose from the pump to the Schrader fitting on the end of the MICRO-BLASTER™ II hose. With feet firmly planted on the bottom of the pump raise the "T" handle and quickly and forcefully depress the "T" handle. It is only practical to fire one MICRO-BLASTER™ Head with this air source given the low volume output of these pumps. Smaller "frame" type bicycle pumps are not recommended, as their outputs are not sufficient to trigger the MICRO-BLASTER™ II reliably. Foot-operated pumps also work well.

PORTABLE AIR TANKS

Although you can fire a single MICRO-BLASTER™ II head with this pressure source, the bulk of these tanks (generally 5 gal. and larger) will make them impractical when working in remote areas. The primary use of

these tanks is for firing more than one MICRO-BLASTER™II unit simultaneously (see tips section, "Multiple Simultaneous Shots With The MICRO-BLASTER™ IIX3"). If you have more than one MICRO-BLASTER™II Head and your system came with "manifold/slide-valve with quick connects", you will only need to connect your components together to configure a system capable of multiple simultaneous shots. Consult your dealer or EZEBREAK for availability and pricing.

CO2 CYLINDERS

Small CO2 cylinders offer another pressure source for triggering the MICRO-BLASTER™ II system. Output pressure should be regulated to 150 psi maximum. A 5 lb. CO2 cylinder when filled should yield 400 or more MICRO-BLASTER™ IIX3 shots when using all 3 heads simultaneously.

The Micro-Blaster™ II Firing Pin

SHOULD ALWAYS MOVE FREELY

AND IT SHOULD ALWAYS BE VISIBLE PORTRUDING

FROM THE BOTTOM OF THE FIRING TUBE. THE PIN

DOES NOT STAY UP AND DOES NOT STICK TO THE

PISTON BY MAGNETISM!!!

WHEN THE UNIT IS READY TO FIRE, THE PISTON

LATCHES TO THE MAGNET. THE FIRING PIN

ITSELF DOES NOT MAGNETIZE AND IT SHOULD BE

PORTRUDING FROM THE BOTTOM OF THE FIRING
TUBE!!!!

STEP BY STEP INSTRUCTIONS
TO BE FOLLOWED IN THE ORDER PRESENTED!
DO NOT USE THIS SYSTEM IF YOU DO NOT
FULLY UNDERSTAND THESE INSTRUCTIONS.
!!!!SERIOUS INJURY MAY RESULT!!!!

1. Determine where you are going to drill your hole. Then stretch out the MICRO-BLASTER™ II hose to its full length away from the material to be broken. If you are breaking the side of a large rock, stretch the hose to the opposite side of the rock away from where the broken pieces are expected to move. At this point, invert the MICRO-BLASTER™ (tip upwards) and tap Steel Cap (1) against a solid object to ensure the Piston (6) is in contact with the Magnet (5) and check for free movement of the Firing Pin (9) (See diagram at the end of this manual for clarity). **Free movement of the firing pin is crucial for safe and effective operation! Inspect your unit often and disassemble, clean and re-lubricate if pin does not move freely! SERIOUS INJURY COULD RESULT IF FIRING PIN DOES NOT MOVE FREELY!**

2. Drill a straight 5/16" hole, no more than 10" deep for 1 cartridge, (12" for 2 cartridges, 14" for 3 cartridges, and 16" for 4 cartridges), in the rock or masonry you intend to break. **Use only 5/16" diameter drill bits for best results!** If you are using drill bits capable of drilling holes deeper than 10" painting a mark on the drill bit at this distance from the end will greatly aid in drilling holes to the proper depth (Ezebreak supplies marked 12" and 16" SDS+ bits). The use of a new and sharp carbide masonry bit is highly recommended. Light pressure on the drill when drilling is generally all that is needed. In very hard materials, use only light pressure to avoid overheating the bit. Heavy pressure does not significantly improve drilling progress and can drastically shorten the life of the bit. Bits should also be alternated between holes to prevent overheating of the carbide tip and allowed to air cool. This practice will substantially lengthen the life of the bit. Never cool in water as sudden cooling of the hot carbide chip at the end of the bit may create micro cracks, which will also shorten the life of the bit.

3. In the next step, the hole should be cleaned of all debris and rock dust that was generated during the drilling process. Holes only need to be cleaned to a depth that is just longer than the length of the Firing Pin Tube (8). Use the HOLE BLOWER supplied with your MICRO-BLASTER™ II Kit to blow out the drilling dust. Compressed air blow guns are also effective as long as the tube delivering the air is of sufficient length to reach a depth 1

inch longer than the length of the Firing Pin Tube (8) After blowing out the hole, run the BORE BRUSH in and out of the hole to remove any packed rock dust from the sides of the hole and follow by again blowing out the loosened dust from the hole with the HOLE BLOWER or compressed air gun. **It is critical that the holes are cleaned thoroughly!** Most misfires can be attributed to rock dust falling on top of the Cartridge in the hole as the tip of the MICRO-BLASTER™ is introduced into the hole which isolates the primer in the end of the Micro-Blaster™ Cartridge from the Firing Pin (9). Avoid misfires by thoroughly cleaning in and around drilled holes. In the case of a misfire (cartridge not firing after system is fired), carefully follow the instructions in the **MISFIRES** section of this manual.

4. Next, make sure that the MICRO-BLASTER™ Firing Pin Tube (8) can be inserted in the drilled hole to its full length. A snug fit is OK, as it will help to hold the MICRO-BLASTER™ head in place when the Cartridge is initiated. If the hole is too tight to allow insertion of the Firing Pin Tube (8), running the rotating drill bit in and out of the hole will ream out the hole to the proper dimension and dislodge packed rock dust that the HOLE BLOWER or BORE BRUSH did not remove. This may not help if the drill bit is worn and has become undersized or the hole is not drilled straight. Check bit diameter if reaming, followed by careful cleaning of the hole, does not solve this problem. Replace the drill bit if it is found to be drilling undersized holes. **Do not go on to step 5 until completion of this step is accomplished and the hole has been properly cleaned and sized to allow complete insertion of the entire Firing Pin Tube (8)!!**

5. Insert MICRO-BLASTER™ Cartridge(s) into the **cleaned** and **checked** hole, making sure that the end of the Cartridge with the metal primer is positioned correctly (facing out of the hole). This will allow the primer at the end of the Cartridge to make proper contact with the tip of the MICRO-BLASTER™ Firing Pin Tube (8) when it is inserted into the hole in the next step. If steps 3 and 4 were properly completed, the Cartridge(s) will slide easily into the drilled hole. **NEVER FORCE A MICRO-BLASTER™ CARTRIDGE INTO THE HOLE. EXTREME INJURY MAY RESULT!**

6. Having successfully completed the above steps you are now ready to insert the MICRO-BLASTER™ Firing Pin Tube (8) into the hole on top of the Cartridge(s). Proceed by sliding the tip of the MICRO-BLASTER™ Firing Pin Tube (8) into the hole and **firmly seat the Micro-Blaster™ on top of the Cartridge(s) by applying no more than 10 pounds of pressure to seat the Cartridge(s) in the hole!** At this point, we recommend that a suitable mat or carpet be placed over the MICRO-

BLASTER™ and the material being broken to eliminate all fly rock and to reduce the sound.

7. Retreat to the end of the hose making sure that no one is in the area where you have been operating and initiate your MICRO-BLASTER™ II by pressurizing the system. After the shot, it is good practice to invert the MICRO-BLASTER™ II, allowing the Piston (6) to make contact with the internal Magnet (5), the "latched" position. You will hear a click. This will prepare your unit for the next shot. A gentle tap of the head with the Firing Pin Tube (8) pointed up against a solid object should ensure "latching" of the Piston (6) onto the Magnet (5). Always store the MICRO-BLASTER™ II with the Piston (6) "latched" to the Magnet (5).

CARE AND MAINTENANCE

!! IMPROPER MAINTENANCE CAN LEAD TO MISFIRES !!

The EZEBREAK MICRO-BLASTER™ II is a precision instrument. In order to get superb performance from the system, it is necessary for the user to maintain it at top condition. Periodic disassembly and cleaning are recommended. The diagram at the end of this manual shows an exploded view of the MICRO-BLASTER™ II. Parts #2 - #5, which make up the magnet assembly, as well as parts #7 & #8, are assembled with a permanent thread locking compound. The user should not attempt to disassemble these components. In the unlikely event that these assemblies become damaged, return them to the manufacturer, after receiving return authorization, for repair or replacement. To disassemble, remove the threaded Steel Plug (1) from the end of the Body (7) and then remove the Firing Pin (9), Piston (6), and Magnet assembly (2-5) by pushing the "L" shaped Ejector Pin up the Firing Pin Tube (8) against the Firing Pin (9) which will in turn push the Piston/Magnet assembly (2-6) out of the Body (7). After disassembly and careful cleaning, components should be lubricated with a light, low viscosity oil such as Rem-Oil™ or a similar product. It is important to use a very "thin" lubricant especially when using your MICRO-BLASTER™ in cold weather. This will avoid drag on the internal components, which can dampen the action of the Piston (6) on the Firing Pin (9) and lead to misfires. After thorough cleaning, insert the Firing Pin (9) into the Firing Pin Tube (8) and check for free movement. If the Firing Pin (9) does not move freely, check for straightness of both the Firing Pin Tube (8) and the Firing Pin (9).

If either part is bent they should be replaced!

Before putting the Piston (6) into the bore of the Body (7), first allow the Magnet assembly (2-5) to attach itself to the flat end of the Piston (6) and center the Magnet (5) on the flat end of the Piston (6). This will align these components properly when re-inserted into the Body (7). This is very important since incorrect positioning of these components may not allow the Magnet (5) to exert its full force on the Piston (6) which in turn will reduce the striking force of the Piston (6) against the Firing Pin (9) when the system is pressurized. Care should also be exercised when tightening the Steel Plug (1). Over-tightening can distort the urethane washer, which suspends the centered Magnet assembly (2-5) in the bore of the Body (7), leading to misalignment with the Piston (6). Tighten this Steel Plug (1) by holding the Body (7) in one hand and tightening the Steel Plug (1) with a 1-1/8" wrench in other hand so as to not over tighten.

After reassembling your MICRO-BLASTER™ II, test it to determine that the Firing Pin (9) moves freely and then apply pressure to "dry fire" the unit to make sure that it is functioning properly. If the tip of the MICRO-BLASTER™ II is held against a piece of wood when "dry firing", the Firing Pin (9) should create a noticeable dent. **Do not "dry fire" against hard materials as damage to the firing pin may result.**

MISFIRES

Most misfire events stem from either not properly cleaning the drilling dust from the hole, not seating the Cartridge firmly at the bottom of the hole, or failing to make sure that the Piston (6) is "latched" with the Magnet (5). Hole cleaning is critical to proper operation of your MICRO-BLASTER™, as already stated, and must be performed thoroughly. Improper maintenance can also contribute to misfires. Keep your MICRO-BLASTER™ in top condition, making sure there is free movement of the Firing Pin (9) and Piston (6) to avoid these problems.

- 1.** In the event of a misfire, wait for at least **1 minute** before approaching the blast area.
- 2.** Carefully withdraw the MICRO-BLASTER™ II from the drilled hole. Check to see if MICRO-BLASTER™ II has fired. Additionally, you can remove the Cartridge(s) and inspect it using the Magnetic Retrieval Tool included with your kit. If you are unable to remove the Cartridge follow the steps below.

3. Using the Hole Blower, blow out the hole, taking care not to accidentally allow any foreign materials to enter the hole. If possible, look down the hole using a small flashlight and see if the primer at the end of the Cartridge(s) has been indented by the action of the Firing Pin (9). If no indentation, or a very small indentation is seen in the primer, the Cartridge(s) may not have been seated firmly at the bottom of the hole or the whole was drilled too deep to allow proper contact between the Firing Pin (9) and the primer end of the Cartridge(s).

4. Re-set the Piston (6) in the firing position by pointing the Firing Pin Tube (8) upwards, tap Steel Plug (1) against a solid object, listening for the click indicating the Piston (6) has made contact with the Magnet (5) inside (see diagram for clarity). Check Firing Pin (9) for free movement.

5. Reintroduce the MICRO-BLASTER™ into the hole and firmly seat on top of the Cartridge using no more than 10 to 12 pounds of force to seat the Cartridge(s).

6. Observing all safety precautions, re-fire the MICRO-BLASTER™. If this step fails to fire the Cartridge(s) again, wait at least 1 minute before approaching the MICRO-BLASTER™. Withdraw the unit from the hole and inspect for an indented primer or foreign material on top of the Cartridge(s).

7. If attempts to re-fire the Cartridge(s) fail and the Cartridge(s) cannot be removed with the aid of the Magnetic Cartridge Retrieval Tool, remove the MICRO-BLASTER™ from the hole and fill with water to deactivate the Cartridge(s). MICRO-BLASTER™ Cartridges are made from a paper tube, which will allow the water to penetrate and deactivate the propellant within one hour.

8. If the material you were trying to break had a "misfire" event, drill a second hole no closer than 2" and parallel to the "misfire" hole taking care not to intersect with the "misfire" hole. **Do not attempt to drill out the "misfire" hole! Serious injury may result!** After drilling the new hole, thoroughly clean the new hole and proceed as usual with the prescribed sequence of operations detailed above.

**NEVER LEAVE AN UNEXPLODED CARTRIDGE IN THE
MATERIAL BEING BROKEN WITHOUT DEACTIVATING
OR REMOVING IT FROM THE HOLE!
!!!!SERIOUS INJURY MAY RESULT!!!!**

TIPS

This next section of this manual contains a few short tips on using your MICRO-BLASTER™. The user should read this information to gain further insight into the many aspects of using the system. If you have any suggestions or tips for other users, email us, and if they seem useful, we will publish them on the EZEBREAK website and give you full credit for your contribution.

BASIC STRATEGY

The drawing on Page 15 illustrates the basic strategy of breaking materials. The first rule in using your MICRO-BLASTER™ is to position the MICRO-BLASTER™ Cartridge(s) in the center of the mass to be broken. A second and equally important rule is to give the material a place to move to when broken. This is of less concern when breaking boulders on top of the ground because they are not surrounded by materials, i.e. dirt, clay, etc. These materials act as physical extensions of the material being broken which effectively increases the required energy needed for breakage. When dealing with buried rock, as in a trench or excavation, these materials should be removed from around the rock in order to expose more of the rock's surface. This will help in determining the appropriate strategy as to where to drill holes. It will also reduce the number of Cartridges required to break the material by lessening the resistance created by the surrounding materials.

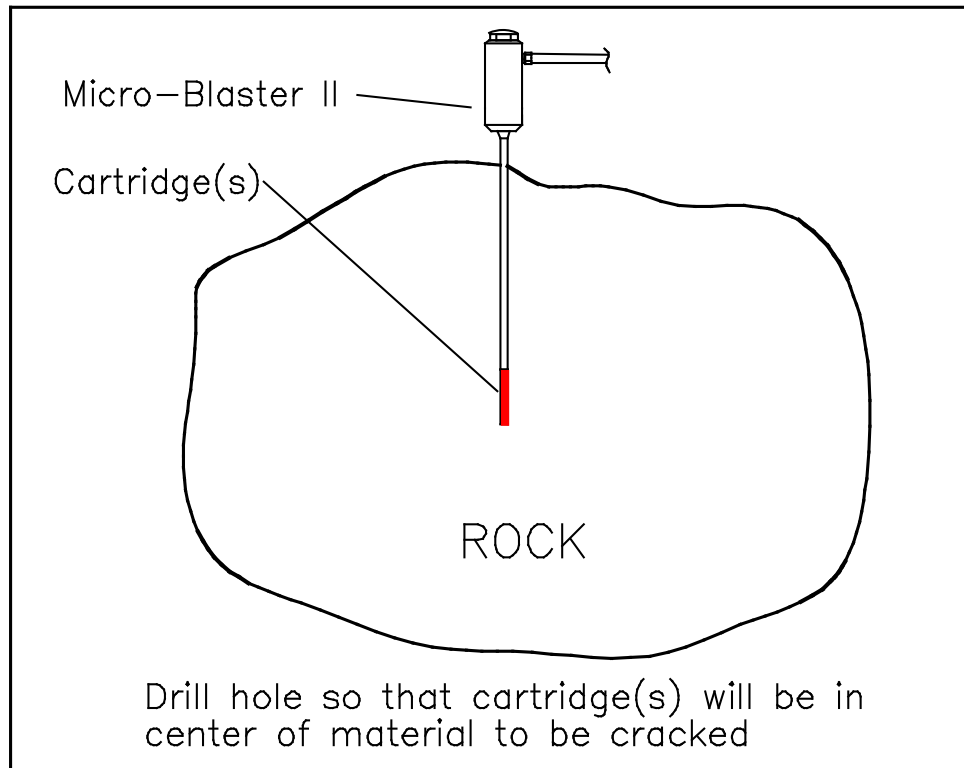

Breaking Larger Rock Using 2+ Cartridges in the Same Hole

On projects where larger rock or softer materials (i.e. concrete) must be broken, the use of up to four MICRO-BLASTER™ Cartridges in the same hole has proven to be extremely effective. We estimate that a fourfold increase (4X) in the effective power can be expected over the use of a single Cartridge in a hole. When anticipating that more than one Cartridge will be required to effectively break the material at hand, the 5/16” diameter holes should be drilled to a depth of 12” for two cartridges, 14” for 3 cartridges, and 16” for 4 cartridges. Drill bits marked for proper drilling depths are available from Ezebreak or our dealers.

Since the resulting “blast” will be increased when using more than one Cartridge in the same hole, we recommend a suitable mat (carpet works well) be placed over the material to be broken to avoid fly rock issues and reduce the sound.

Whether using one or up to four Cartridges, the cleanliness of the drilled hole is always extremely important and should always be cleaned thoroughly to ensure dependable results from your MICRO-BLASTER™, avoiding time consuming misfires.

Breaking Large Rocks

This tip is primarily to allow users of MICRO-BLASTER™ to break larger masses using single MICRO-BLASTER™ units. If using a MICRO-BLASTER™ IIX3 kit, refer to the section "Multiple Simultaneous Shots With The MB-IIX3". To break large rocks, or to break off larger pieces of rock with the MICRO-BLASTER™, a technique known as "pre-splits" will allow one to break up rocks weighing over 10 tons. The technique involves drilling a series of holes along a line, defining where the rock is to be broken. This is similar to the technique employed since Roman times using tools known as "plugs and feathers" or "wedges and feathers" and is still used today in dimensional stone quarries to make predictable cuts. The most noticeable example of the use of this concept, on a large scale, can be seen along the sides of highways where deep cuts were made in the surrounding terrain to allow construction of a road. The parallel vertical lines (1/2 of the original drilled holes) are evidence of the accuracy and effectiveness of "pre-splits".

Experience with the material being broken will allow the user to make decisions on the spacing of holes. Lacking that, a good starting point would be to space your holes a few inches apart and then fire the MICRO-BLASTER™ in one of the middle holes. The first shot may not break off any material, but close examination should reveal a hairline crack emanating from the hole and connecting some or all of the other holes. Remember, holes prepared for Cartridges always need to be cleaned thoroughly just before loading and firing. The other holes not being used for Cartridges do not require cleaning. A second shot can be done in one of the other holes as long as the crack connecting the holes is not too large and the hole has been thoroughly cleaned. Cracks can allow the expanding gases from the second fired Cartridge to escape too rapidly to be effective for further breakage of the rock.

If the second shot does not open or extend the original hairline crack from the first shot, the following things need to be considered:

1. The crack may be allowing too much of the gas to escape.
2. The spacing of the drilled holes needs to be reduced.
3. The line of holes needs to be drilled closer to a free edge.

If you decide that too much gas is escaping, you will now need to use the tapered pins supplied in the MICRO-BLASTER™ kit to wedge apart the broken rock. For most rocks, placing the two pins at 1/3 intervals along the line of holes, and then alternately striking the pins should finish the split. For especially large rocks more pins may be called for to exert greater splitting force.

In general, softer materials will need the holes to be drilled closer together than harder materials. This is primarily because the softer materials tend to absorb more of the energy created by the MICRO-BLASTER™ Cartridge. Concrete, partly because of its relative softness and the presence of the aggregate within (which breaks up the fracture lines), may require spacing of holes as close as 6" apart. Very hard fine-grained rock such as granite or limestone may be effectively broken with the spacing of holes as far as 18"-24" apart. When breaking rock with distinct layers, holes drilled parallel to the layers are often more effective than holes drilled at right angles to or through the layers (i.e. sandstone).

After some experience using the MICRO-BLASTER™ with specific materials, spacing of the holes will become more predictable. Furthermore, an organized and methodical approach to your projects will greatly improve productivity. Take notes and refer to them as your experience grows.

Breaking Off the Tops of Rocks



1. On one side of the rock, dig down below the grade several inches.
2. Drill the hole below the grade at a shallow downward angle into the rock, being careful to make sure that the bottom of the 10" deep hole is near the middle of the rock to be broken.
3. Thoroughly clean the hole and proceed as usual observing all safety precautions previously stated. On very large rocks several holes may have to be drilled and shot from different sides.

Breaking Concrete

Concrete, because of its relative softness and the aggregate it contains, will require more shots to be placed closer together than when breaking hard rock. Experience has taught us that in most concrete breaking projects, 2 Cartridge shots with 12" deep holes are required. Large masses containing rebar and reinforcing wire can be successfully broken by using successive shots starting at a free edge or corner and progressing through the mass. This creates a series of small cracks that can be broken apart with a jack or hydraulic hammer much faster and easier than without pre-cracking.

Concrete slabs and poured walls (see drawing pg. 19), given their relative thinness, should be drilled in the center of an exposed edge. This will allow holes to be drilled to their proper depth (10" for single Cartridge shots and 12" for 2 Cartridge shots, etc.). If no edge is exposed, very shallow angled holes can be drilled and shot in the concrete (floors or walls). The user should take care to drill the holes so that the bottoms of the holes are near the center of the thickest part of the material to be broken. To drill these shallow holes, begin by drilling at right angles to the surface (approximately ¼" deep) and then, while the bit is rotating, tilt the drill to the angle required. Be careful not to drill too deeply when starting the hole, as you may damage the tip of the drill bit when tilting to the shallow angle required. Pre-scoring the outline of the opening with a masonry saw, then MICRO-BLASTING™ the material out will provide a more finished appearance to the opening if required. It is good practice to score as deeply as possible and if accessible, to score from both sides. Holes drilled in the corners of the area to be removed through the wall or floor will aid in the proper alignment of these scored lines and should be done before scoring. Drilling in these slots may cause the tip of the drill to jam and damage the bit.

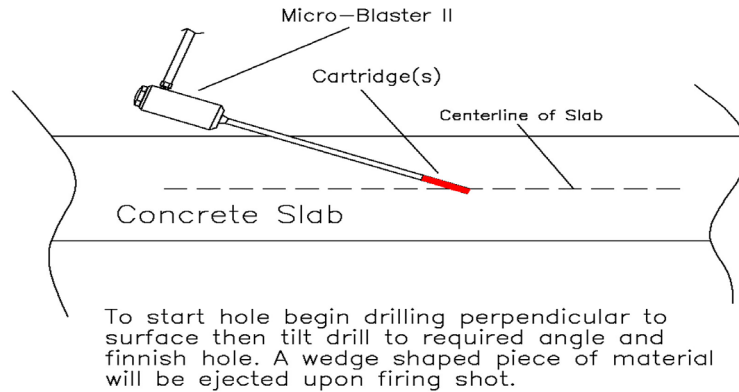

Multiple Simultaneous Shots With The Micro-Blaster™ IIX3

Much larger masses of material can be broken using the MB-IIX3 Kit. Rocks weighing several tons have been broken in one shot using an MB-IIX3 Kit. This can be accomplished by attaching the hoses from the three MICRO-BLASTER™ II Heads to the slide-valve/manifold assembly

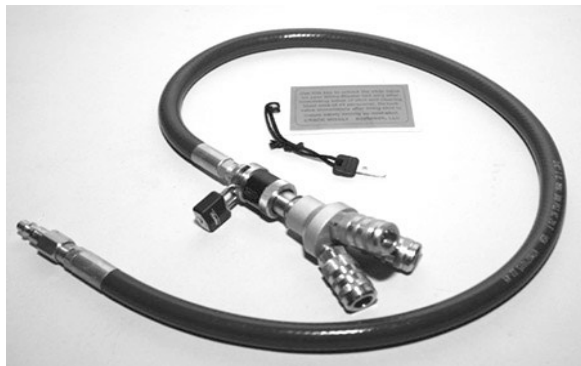

included in the MB-IIX3 kit (see pic). This configuration must be fired using an auxiliary pressure source, such as a portable air tank or portable compressor (100 psi min.), **not a CO2 inflator**. This is because a 12 or 16 gram CO2 inflator will not dependably supply the volume of gas to trigger more than one head simultaneously.

When using the Micro-Blaster IIX3, the user should drill the multiple holes required in the same plane and in line with each other to avoid the potential of rock moving in different directions, which could bend or break the firing pin tubes on the MB-II bodies.

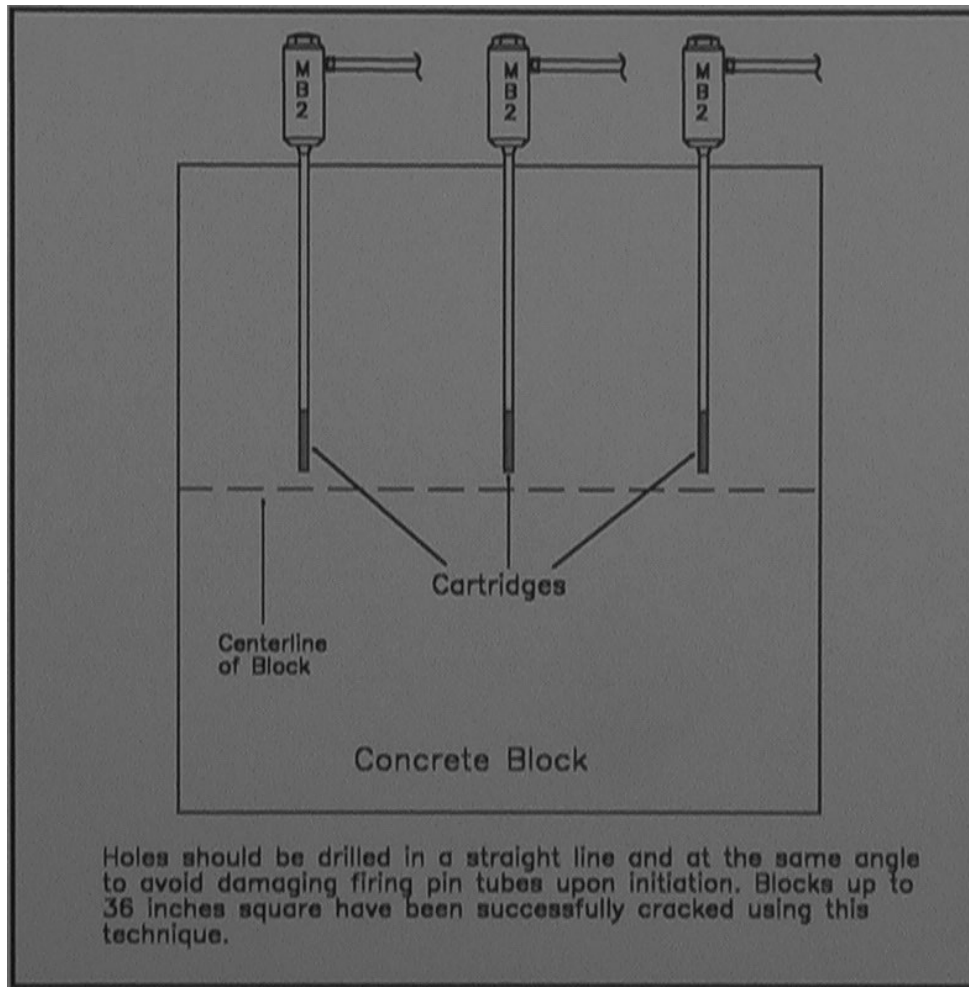

For the breaking of any material, especially for larger masses, the user should never drill holes on different sides and at different angles. This could force large sections of the broken rock to move in opposition to one or more of the MICRO-BLASTER™ Firing Pin Tubes that are embedded in the rock. This movement combined with the force created by the shot could damage the firing pin tubes and/or firing pins resulting in the unit needing factory repair. Keep holes in a line and drill at the same angle to avoid damage to your MICRO-BLASTER™ II units. ***An exception to this rule would be the removal of only the top of a large boulder or the removal of only a small part of a larger mass, such as in a section of bedrock.***

Conversion and Adapter Kits

MBIIX3-ATCK – Air Tank Conversion Kit

If you already have your own air tank or plan to buy one you may need the components to connect the MICRO-BLASTER™ IIx3 Manifold/Slide Valve

Assembly to your tank. For your convenience we have put together a kit containing the needed components (1/4" MPT 6 Point Coupler, 1/4" FPT x 1/4" Plug End, and Teflon Tape)

MBIIX3-ADAP – MBIIX3 Hose End to Schrader Fitting

To fire only one of the MB-II Heads included in your MICRO-BLASTER™ IIX3 Kit by using a CO2 Inflator or "T" Handle Bicycle Pump you will need an adapter (available from Ezebreak) that consists of a MPT 6 Point Coupler attached to a Schrader fitting.

MB-II Schrader End to MB-IIX3 Quick Coupler End

In order to use your MB-II unit with the tire valve fitting (Schrader Fitting) on the hose end with the slide-valve/manifold assembly pictured above you will need to change your hose end fitting. You will need to exchange your Schrader fitting for a 1/8" MPT to 1/4" Industrial Interchange Quick Coupler Plug (available from Ezebreak)

EZEBREAK, LLC WARRANTY & TERMS

All products manufactured by Ezebreak are covered by warranty for a period of 90 days from the date of original purchase against defects in materials and workmanship. If the product fails during this period Ezebreak will assess the damage, and if found to be defective in either workmanship or materials, Ezebreak will repair and return or replace defective products without charge to the customer. To return products suspected of being defective, users must first obtain a Return Authorization Number (RMA) from Ezebreak by calling 888-497-9970. This number must be clearly marked on the outside of the package. Customers may be required to show information providing Ezebreak with proof of purchase. Ezebreak will not accept any returned products that do not have a prior Return Authorization Number.

This warranty does not cover damage due to normal use or abuse by users. Products damaged in shipment are the sole responsibility of the shipper. All claims need to be made by the shipper to the carrier. It is the responsibility of the shipper to adequately ensure all shipments made by third party carriers.

Ezebreak will, in a timely fashion, report to users their findings as to required repairs and costs, returning products via the most economical means. If, at the sole discretion of Ezebreak, products are found to have been abused during this 90-day period, Ezebreak will advise users of the cost of repair and receive payment for said repairs prior to shipping unless other arrangements have been made.

Neither seller nor manufacturer shall be liable for any injury, loss or damage, direct or consequential, arising out of the use of or inability to use the products. Before and during the use of this product, the user assumes all risk and liability whatsoever in connection therewith. No statement or recommendation not contained herein shall have any force or effect unless in an agreement signed by representatives of manufacturer. All Manufacturer's names and logos are the trademarks of the respective organizations or companies. EZEBREAK reserves all rights as to publication and distribution of all written materials contained herein.
EZEBREAK, ©2002-2026

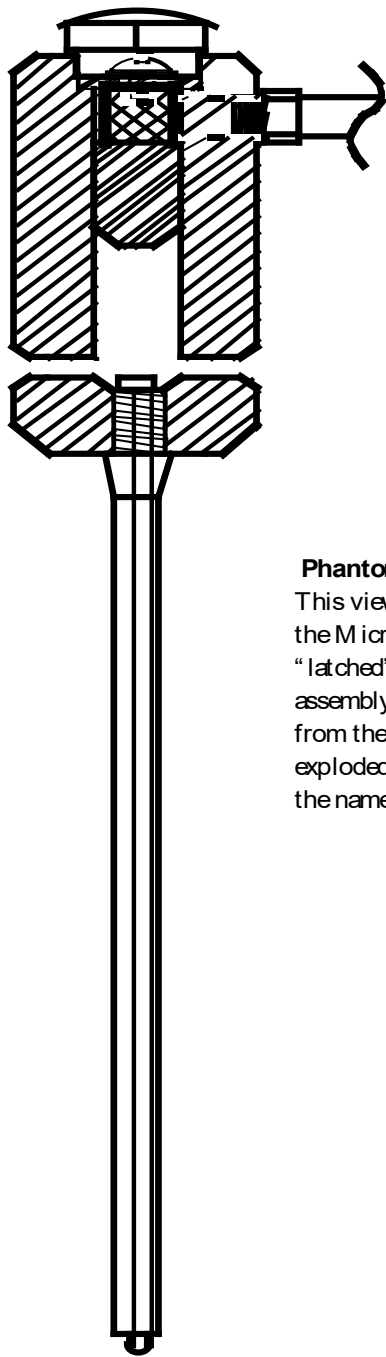

Phantom
This view shows
the Micro-latched
“latched” position
assembly as shown
from the front view
exploded view
the names of the
components.

Micro-Blaster II Components

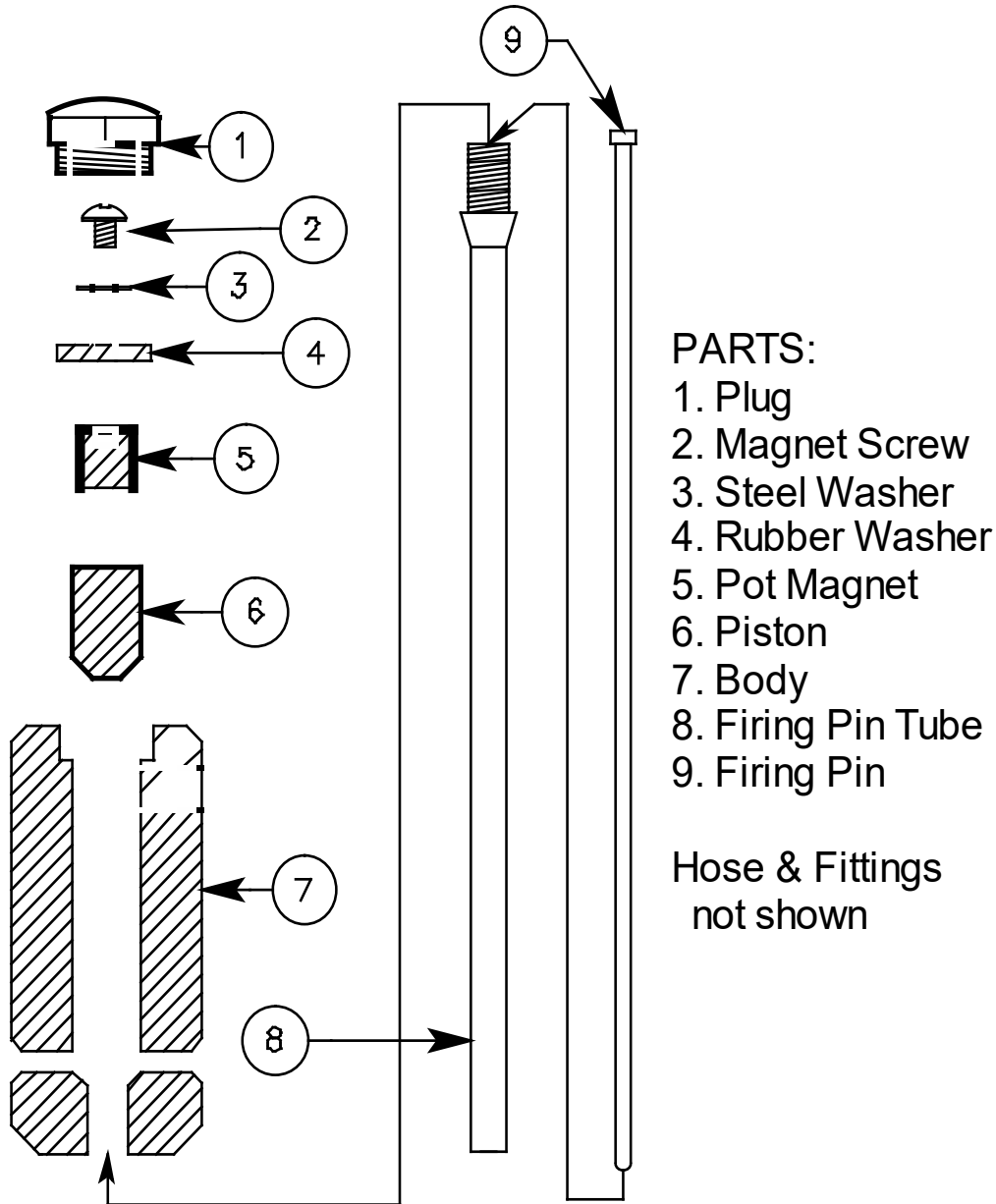

The threads on parts 2 through 5 and 7 and 8 have been assembled using a high strength thread locking compound and are not user serviceable. Return to Dealer or EZEBREAK for repair.

www.ezebreak.com

NOTES: